

STERIMIXER®

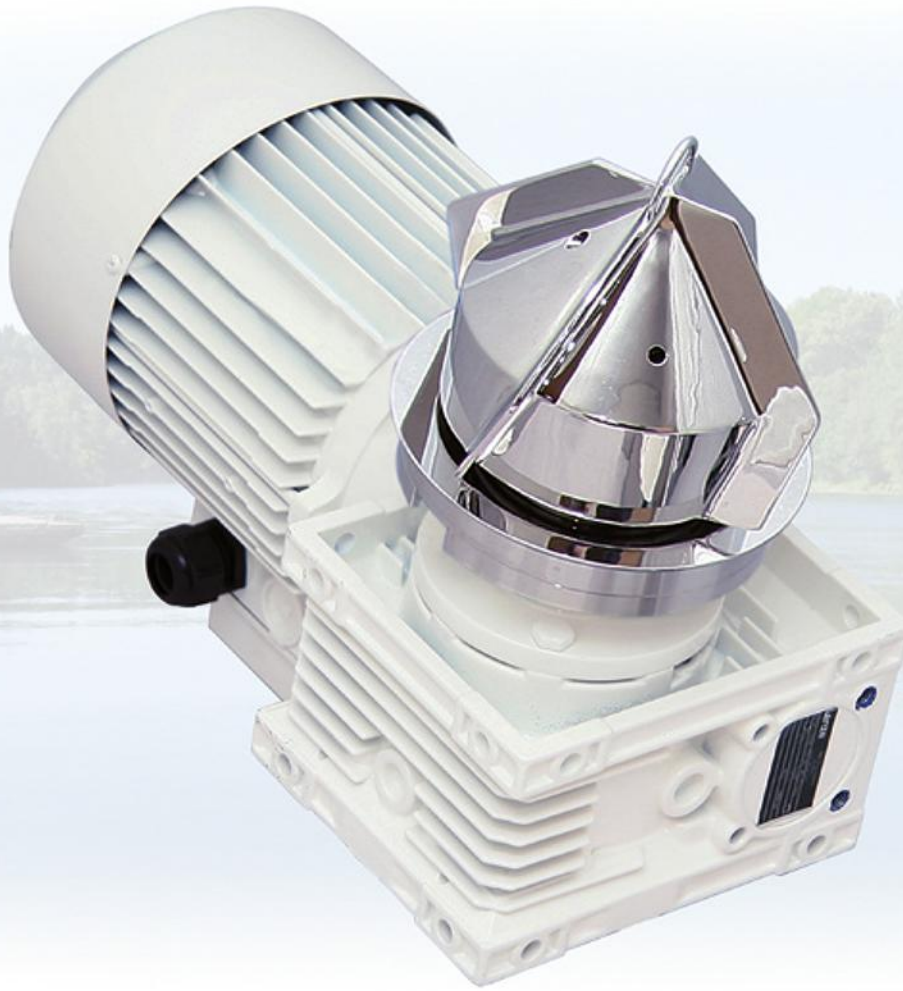

...mixing to the last drop

A unique magnetically coupled mixer

The Sterimixer may be the most widely used magnetically coupled mixer for biopharmaceutical applications world-wide. It consists of the following major components: impeller, bearing, weld-plate, drive unit and control box. All wetted parts of the impeller and the weld-plate are made of AISI 316L stainless steel. Two impeller designs are available: SMA and SMO.

Self purging design – SMA

The SMA impeller has horizontal flow-channels that ensure continuous purging of liquid through the bearing and from beneath the impeller. Therefore the SMA impeller is especially suited for applications with soils that are not easily removed from wetted surfaces during cleaning. Its patent design optimizes CIP performance while running the impeller submerged in the cleaning solution. The SMA is CIP and SIP capable.

Open design – SMO

The SMO impeller features an open design that exposes the interior of the mixer and can be readily cleaned using typical in-vessel equipment - for instance a fixed spray device aimed at the impeller with purge directly to the vessel drain. The impeller does not need to be submerged during the CIP cycle. The SMO is CIP and SIP capable.

Interchangeability

The SMA and SMO impellers both use the same bearing and weld-plate assemblies and are fully interchangeable.

A wide choice of models

Sterimixer models are available for vessel volumes ranging from 5 liters to beyond 20,000 liters, with or without control cabinets and with various types of drive units: AC, AC stainless steel, DC, Air, together with explosion proof and ATEX options. The Sterimixer is manufactured in accordance with relevant industry standards and requirements such as: ASME BPE, applicable pressure vessel codes, material traceability requirements and the EU Machine Directive 89/392/EEC, as well as cGMP.

Total quality concept

Sterimixer manufacturing is quality assured and certified to be in accordance with ISO 9001 by Lloyds Register Quality Assurance. Sterimixer is also provided with all relevant documentation required for validation purposes.

References

Worldwide references for the Sterimixer include the manufacture of blood protein fractions, delicate cell suspensions, insulin, LVPs, vaccines, buffer solutions and oral liquids. Using our experience combined with a history of manufacturing excellence and full technical support, Sterimixer can guide you to obtain the most user-friendly and cost-effective solution for your application. Our Research & Development Center and test equipment are available for confidential customer product testing.

Mixing principle



1- Soluble powder or liquid is added into the vortex. It is then rapidly transported downwards to the impeller.



2- After reaching the impeller, the fluid flows in a radial direction towards the vessel wall.



3- After reaching the vessel wall, the fluid travels upwards and then circulates down to the impeller again. The overall bulk movement and the mixing action around the agitator ensure that a homogeneous concentration distribution is achieved.

Principal Drawing

Impeller

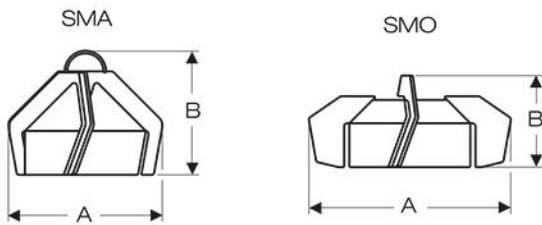

Control box

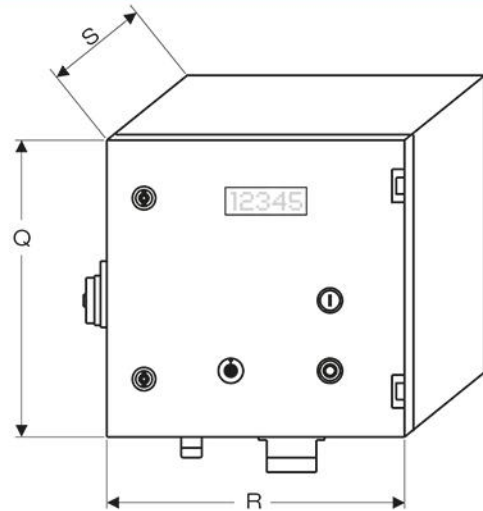

Bearing

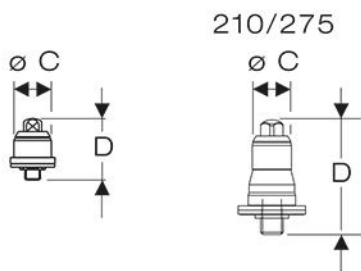

Welding plate

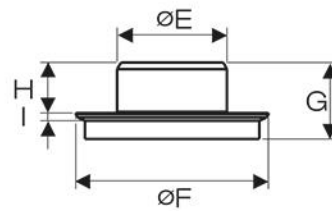

Drive unit

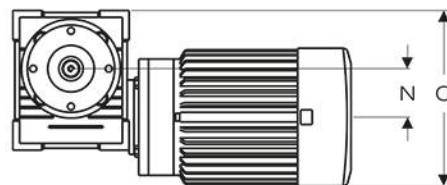
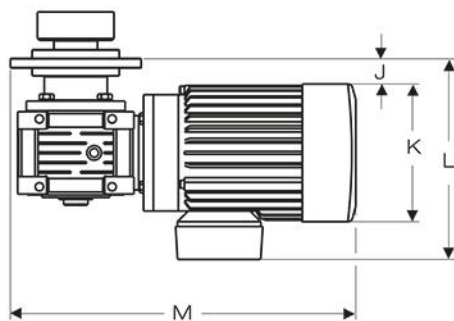

Technical Information

	SMA 60/75	SMO 85/100	SMA 85/100	SMO 85/140	SMA 85/140	SMO 120/150	SMA 120/150	SMO 120/190	SMA 120/190	SMA/SMO 120H/220	SMA/SMO 210/275	SMA/SMO 210/350
Impeller												
A	78	114	100	145	140	163	155	201	190	200/220	275	350
B	60	71	82	71	82	103	120	110	120	145	140	140
Bearing												
C	17		17				34			35	50	50
D	23		23				50,5			53	85	85
Weld plate												
E	32		54				85			85	168	168
F	60		90				149			150	280	280
G	44		48				59			85	72	72
H	29		28				39			65	52	52
I	5		5				6			5	5	5
Motor	75 W AC		180 W AC			750 W AC		1100 W AC		1500 W AC	2200 W AC	3000 W AC
J	10		7			9		8		8	20	20
K	75		120			158		178		178	191	191
L	133		154			200		219		219	254	254
M	225		275			357		410		410	555	555
N	25		30			50		63		63	75	75
O	76		130			189		224		224	256	256
Control box												
Q						300					360	360
R						300					360	360
S						200					240	240
Options												
Motor DC	X	X	X	X	X							
Motor AIR	X	X	X	X	X	X	X	X	X			
Impeller * Monitor	X	X	X	X	X	X	X	X	X	X	X	X
Extended drive-shaft	X	X	X	X	X	X	X	X	X	X	X	X
Silicon Car- bide bearing	X	X	X	X	X	X	X	X	X	X	X	X
Eex	Please advise room classification, i.e. Eexde IIB T4											
Max torque (Nm)	0,75	1,5				14				26	38	38

Selection Guide and Options

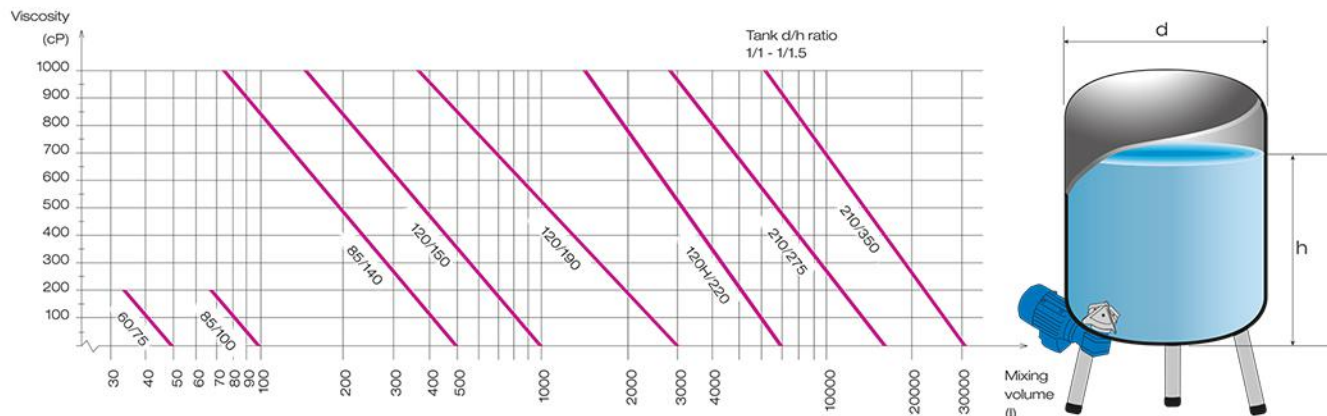

Materials of construction

Bearing material: Tungsten carbide (FDA accepted) – standard
Silicon carbide (FDA accepted)

O-rings and gasket materials: Gaskets - PTFE USP <88> Class VI
O-rings - EPDM or FPM USP <88> Class VI
Other materials are available upon request.

All stainless steel parts: AISI 316L
Other materials are available upon request, e.g. AL6-XN, Hastelloy.

SMA – Sterimixer Closed. SMO – Sterimixer Open.

Surface finish

Europe & Asia

Ra 0.5 µm for all SMO and SMA 210/275-350 models.
Ra 0.2 µm for all remaining SMA models.

North America

Ra 15 µin. electropolished (ASME BPE SF4).
Ra 20 µin. (ASME BPE SF1).

Electropolished finish and passivation are available.

Example: SMO 85/140 180W AC

SMO – Sterimixer Open
85/140 – Impeller body ø 85, wings ø 140
180W AC – Motor 180W AC

Sterimixer type	Vigorous mixing volume, liters (U.S. Gallons)	Gentle mixing volume, liters (U.S. Gallons)
SMA 60/75	5 – 50 (1.5 – 15)	– 100 (25)
SMO 85/100	20 – 100 (5 – 25)	– 200 (50)
SMA 85/140	50 – 500 (15 – 130)	– 1000 (260)
SMO 120/150	300 – 1000 (80 – 260)	– 2000 (520)
SMA 120/190	300 – 3000 (80 – 800)	– 6000 (1600)
SMA 120H/200	1000 – 7000 (260 – 1800)	– 14000 (3700)
SMA/SMO 210/275	3000 – 15000 (800 – 4000)	– 30000 (8000)
SMA/SMO 210/350	3000 – 30000 (800 – 8000)	– 40000 (10500)

The above recommendations assume non viscous fluids, less than 10 cP.
For other fluids, please contact us for a recommendation.



STERIDOSE® ... *purmixing*

STERIDOSE SALES

www.steridose.com

